

## Description

AP5002 consists of step-down switching regulator with PWM control. These devices include a reference voltage source, oscillation circuit, error amplifier, internal PMOS.

AP5002 provides low-ripple power, high efficiency, and excellent transient characteristics. The PWM control circuit is able to vary the duty ratio linearly up to 100%. This converter also contains an error amplifier circuit as well as a soft-start circuit that prevents overshoot at startup. An enable function, an over current protect function and a short circuit protect function are built inside, and when OCP or SCP happens, the operation frequency will be reduced from 500KHz to 50KHz. Also, an internal compensation block is built in to minimum external component count.

With the addition of an internal P-channel Power MOS, a coil, capacitors, and a diode connected externally, these ICs can function as step-down switching regulators. They serve as ideal power supply units for portable devices when coupled with the SOP-8L mini-package, providing such outstanding features as low current consumption. Since this converter can accommodate an input voltage up to 22V, it is also suitable for the operation via an AC adapter.

## Features

- Input voltage: 3.6V to 20V
- Output voltage: 0.8V to  $V_{CC}$
- Duty ratio: up to 100% PWM control
- Oscillation frequency: 500KHz typical
- Soft-start Current Limit, Enable function
- Thermal Shutdown function
- Built-in internal SW P-channel MOS
- Low ESR output capacitor (MLCC, multi-layer ceramic capacitor) support
- Efficiency 90%
- SOP-8L: Available in "Green" Molding Compound (No Br, Sb)

## Pin Assignments

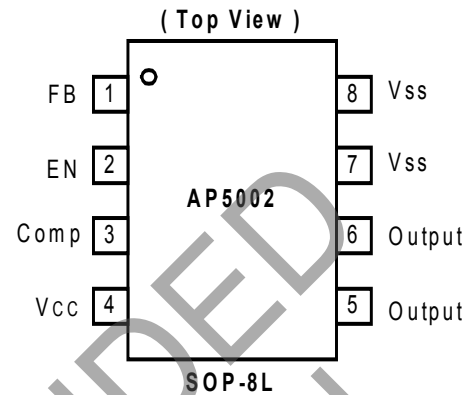

## Applications

- PC Motherboard
- LCD Monitor
- Graphic Card
- DVD Video Player
- Telecom Equipment
- ADSL Modem
- Printer and other Peripheral Equipment
- Microprocessor core supply
- Networking power supply

NOT RECOMMENDED FOR NEW DESIGN

**Typical Application Circuit**

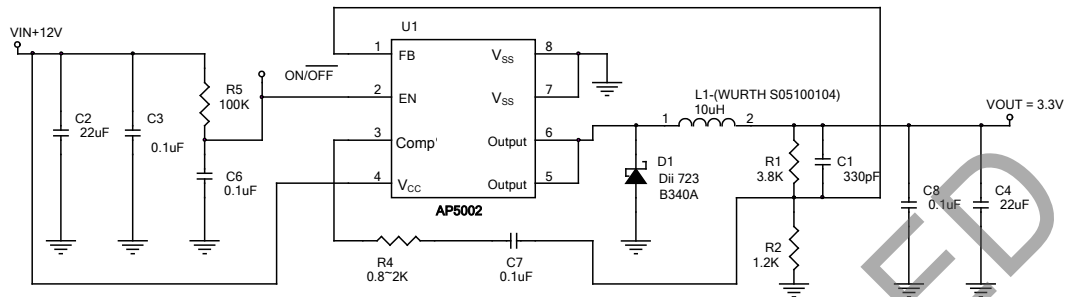

Compensation Capacitor Selection (MLCC)				
VIN	VOUT	R4	C7	C1
12V	5/ 3.3/ 2.5/ 1.8/ 1.5V	0.8~2K	0.1μF	330pF
5V	3.3/ 2.5/ 1.8/ 1.5V	0.8~2K	27nF	330pF

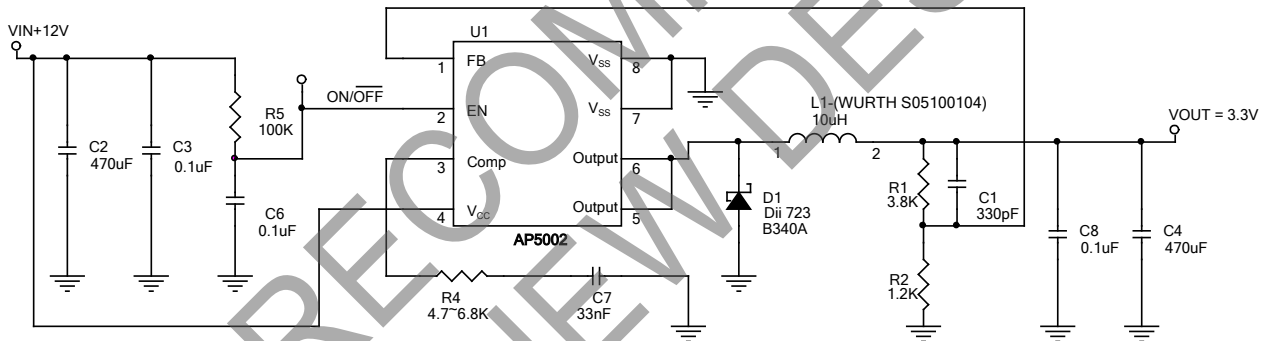

Note: 1.  $V_{OUT} = V_{FB} \times (1 + \frac{R1}{R2})$

## Pin Descriptions

Name	Pin	Description
FB	1	Feedback pin
EN	2	Power-off pin H: Normal operation (Step-down operation) L: Step-down operation stopped (All circuits deactivated)
Comp	3	Compensation pin
V <sub>CC</sub>	4	IC power supply pin
Output	5, 6	Switch Pin. Connect external inductor/diode here. Minimize trace area at this pin to reduce EMI.
V <sub>SS</sub>	7, 8	GND Pin

## Block Diagram

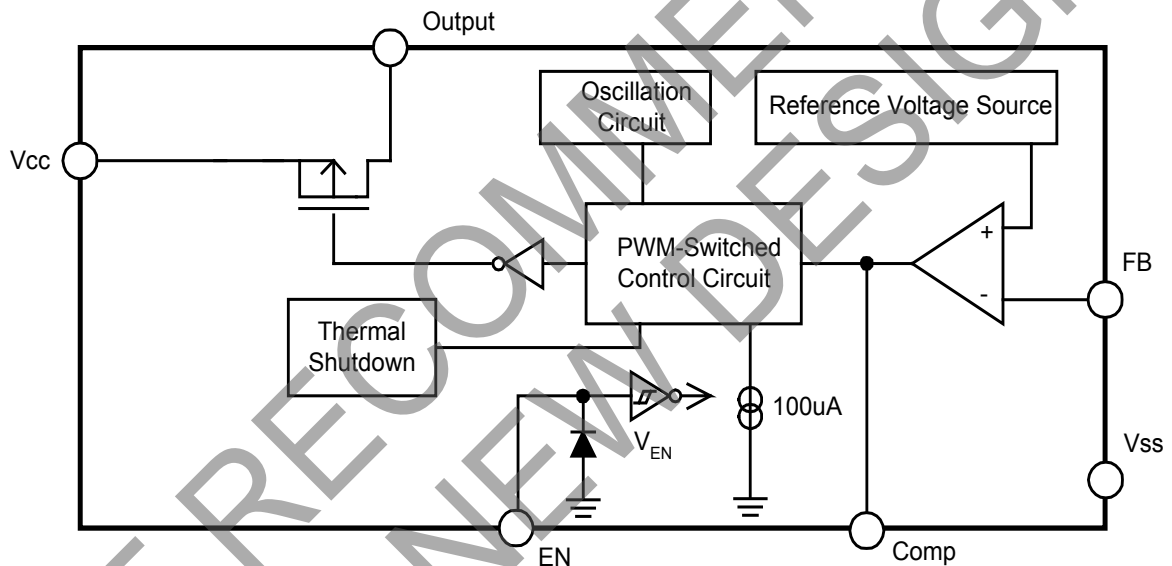

## Absolute Maximum Ratings

Symbol	Parameter	Rating	Unit
ESD HBM	Human Body Model ESD Protection	5	KV
ESD MM	Machine Model ESD Protection	200	V
V <sub>CC</sub>	V <sub>CC</sub> Pin Voltage	V <sub>SS</sub> - 0.3 to V <sub>SS</sub> + 22	V
V <sub>FB</sub>	Feedback Pin Voltage	V <sub>SS</sub> - 0.3 to V <sub>CC</sub>	V
V <sub>EN</sub>	EN Pin Voltage	V <sub>SS</sub> - 0.3 to V <sub>IN</sub>	V
V <sub>OUTPUT</sub>	Switch Pin Voltage	V <sub>SS</sub> - 0.3 to V <sub>IN</sub>	V
P <sub>D</sub>	Power Dissipation	1000	mW
T <sub>J</sub>	Operating Junction Temperature Range	-20 to +125	°C
T <sub>ST</sub>	Storage Temperature Range	-65 to +150	°C

Caution: The absolute maximum ratings are rated values exceeding which the product could suffer physical damage. These values must therefore not be exceeded under any conditions.

## Recommended Operating Conditions

Symbol	Parameter	Min	Max	Unit
V <sub>IN</sub>	Input Voltage	3.6	20	V
I <sub>OUT</sub>	Output Current	0	2	A
T <sub>A</sub>	Operating Ambient Temperature	-20	+85	°C

## Electrical Characteristics (V<sub>IN</sub> = 12V, T<sub>A</sub> = +25°C, unless otherwise specified)

Symbol	Parameter	Conditions	Min	Typ.	Max	Unit
V <sub>FB</sub>	Feedback Voltage	I <sub>OUT</sub> = 0.1A	0.784	0.8	0.816	V
I <sub>FB</sub>	Feedback Bias Current	I <sub>OUT</sub> = 0.1A	—	0.1	0.5	μA
I <sub>CCQ</sub>	Quiescent Current	V <sub>FB</sub> = 1.2 force drive off	—	3	5	mA
I <sub>SW</sub>	Switch Current	—	3.5	—	—	A
I <sub>SD</sub>	Shutdown Supply Current	V <sub>EN</sub> = 0V	—	10	—	μA
$\frac{\Delta V_{OUT}}{V_{OUT}}$	Line Regulation	V <sub>IN</sub> = 4V~20V, I <sub>OUT</sub> = 0.2A	—	1	2	%
$\frac{\Delta V_{OUT}}{V_{OUT}}$	Load Regulation	I <sub>OUT</sub> = 0.1 to 2A	—	0.5	1	%
f <sub>OSC</sub>	Oscillation Frequency	Measure waveform at SW pin	400	500	600	KHz
V <sub>SH</sub>	EN Pin Input Voltage	Evaluate oscillation at SW pin	2.0	—	—	V
V <sub>SL</sub>	EN Pin Input Voltage	Evaluate oscillation stop at SW pin	—	—	0.8	
I <sub>SH</sub>	EN Pin Input Leakage Current	V <sub>EN</sub> = 2V	-10	—	10	μA
I <sub>SL</sub>	EN Pin Input Leakage Current	V <sub>EN</sub> = 0.8V	-10	—	10	μA
T <sub>SS</sub>	Soft-Start Time	—	—	3	—	ms
R <sub>DSON</sub>	Internal MOSFET R <sub>dson</sub>	V <sub>IN</sub> = 5V, V <sub>FB</sub> = 0V	—	110	150	mΩ
		V <sub>IN</sub> = 12V, V <sub>FB</sub> = 0V	—	70	100	
—	Thermal shutdown	—	—	+140	—	°C
—	Minimum Duty Cycle	—	—	6.5	—	%
θ <sub>JA</sub>	Thermal Resistance Junction-to-Ambient	SOP-8L (Note 2)	—	124	—	°C/W
θ <sub>JC</sub>	Thermal Resistance Junction-to-Case	SOP-8L (Note 2)	—	25	—	°C/W

Note: 2. Test condition: Device mounted on 2oz copper, minimum recommended pad layout, FR-4 PCB.

**Typical Performance Characteristics**

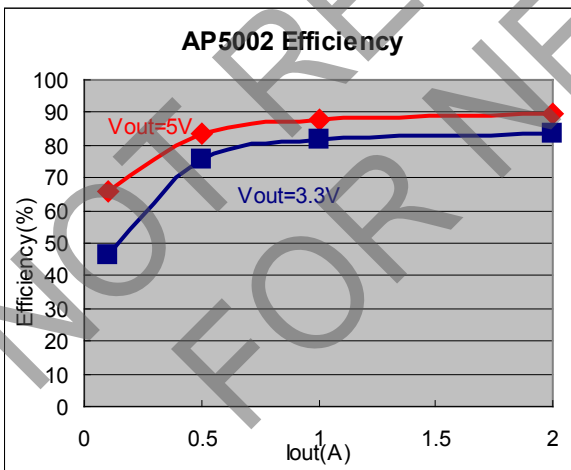
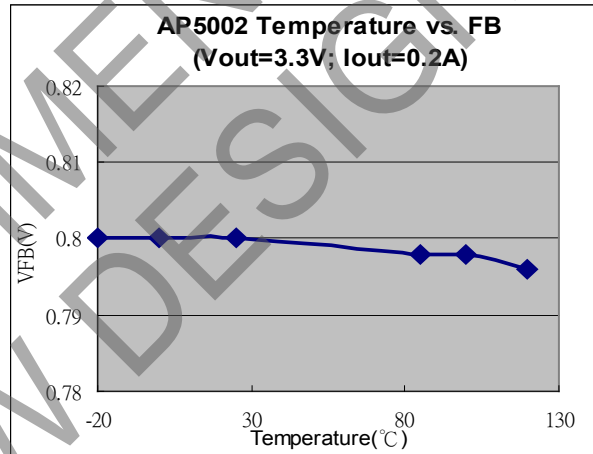
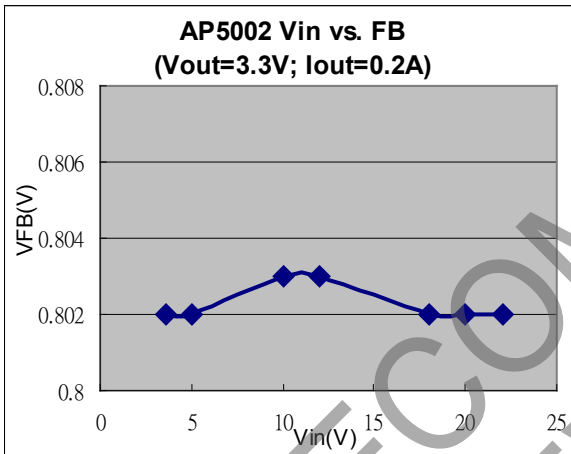
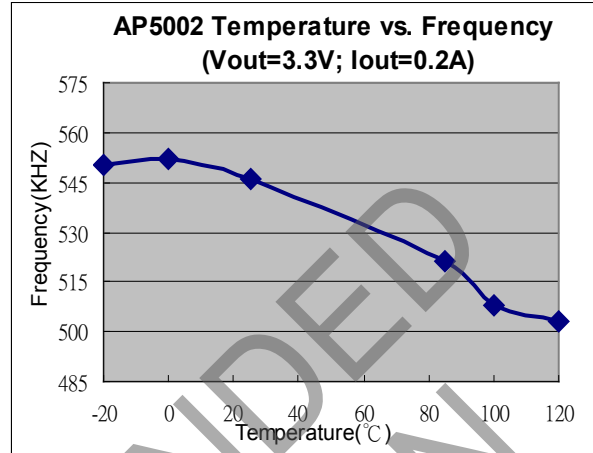
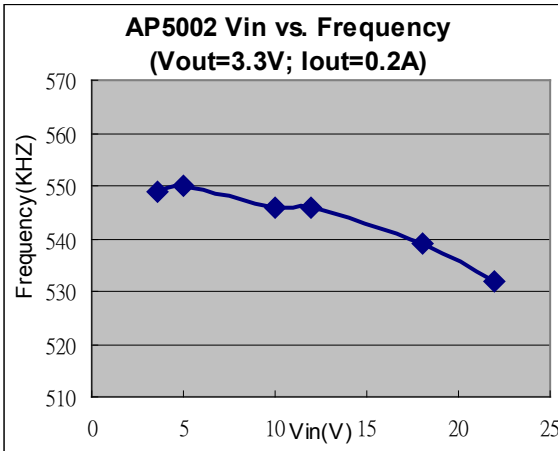

Typical Performance Characteristics (continued)

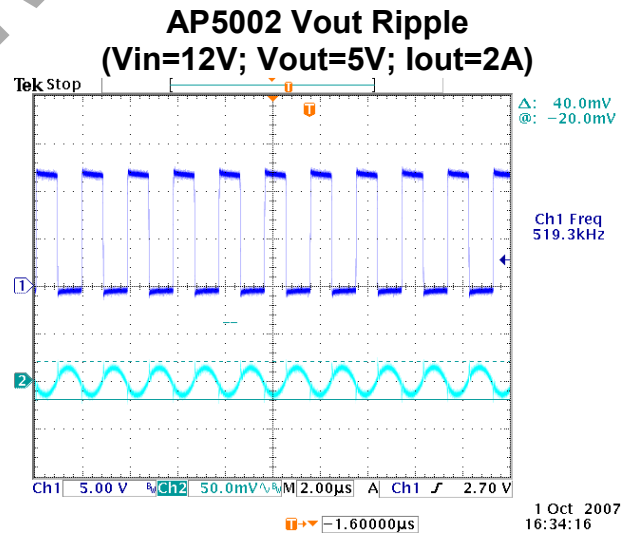
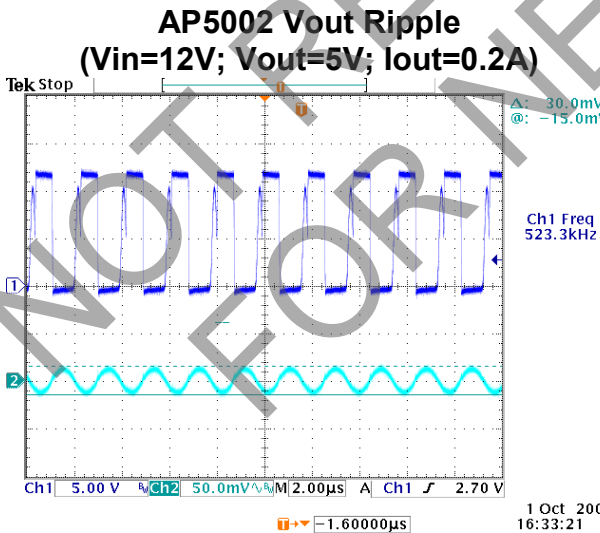
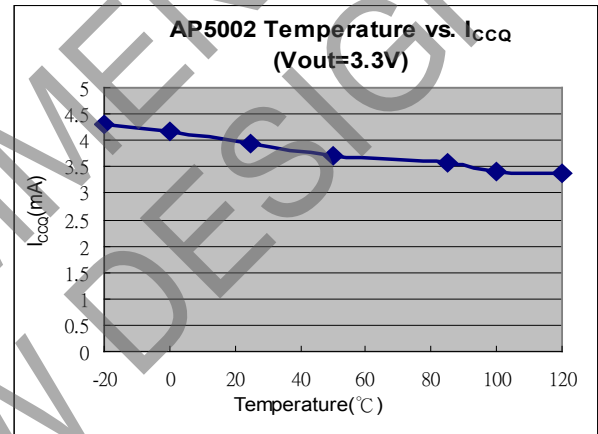
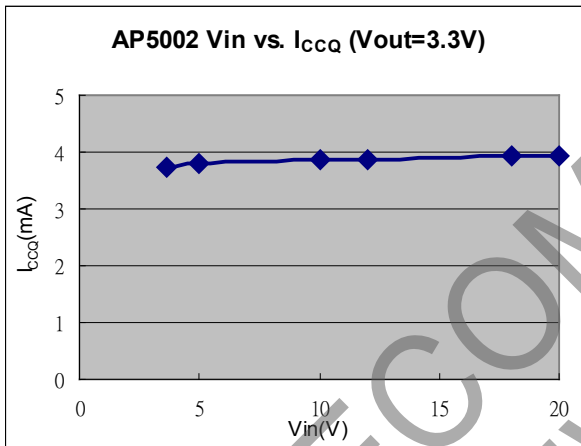
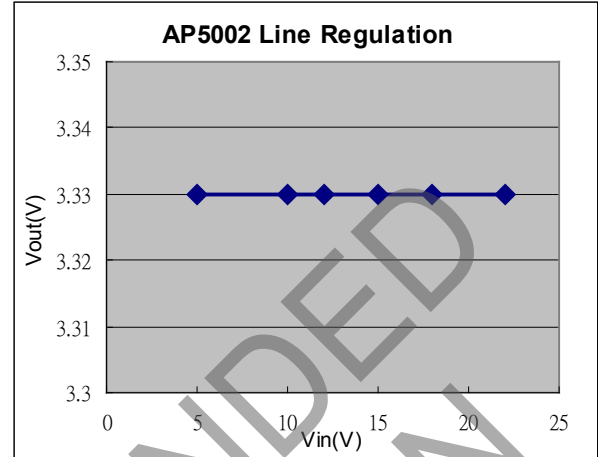
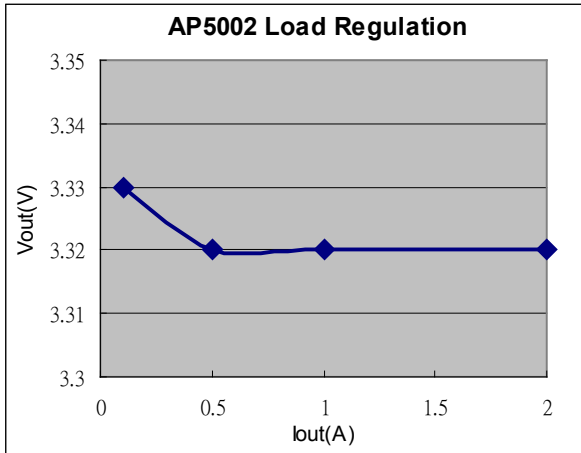

**Test Circuit**

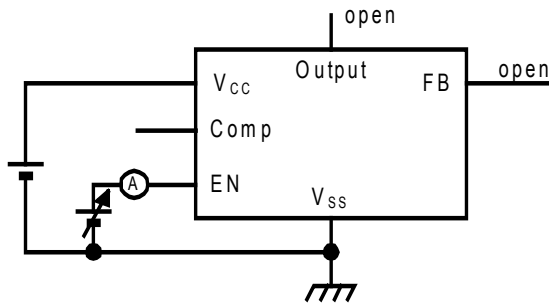

Enable function test

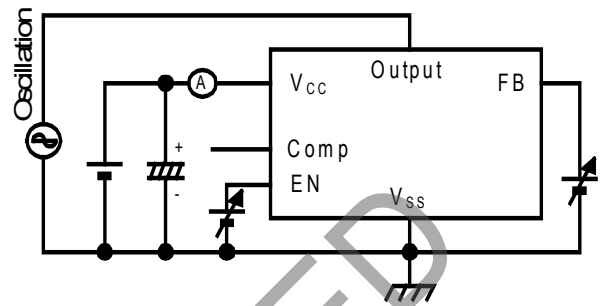

Feedback function test

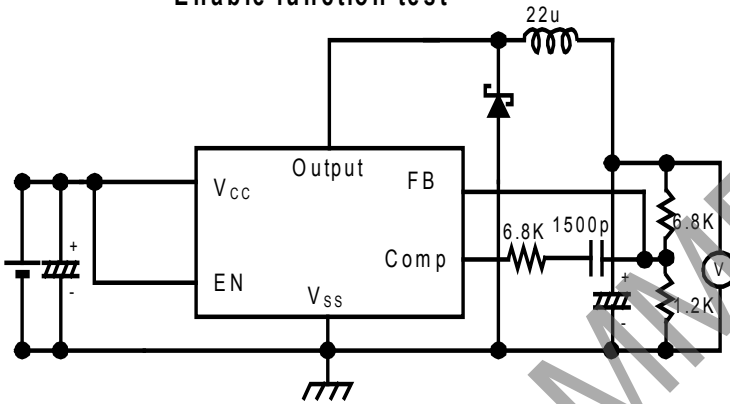

Operation function test

NOT RECOMMENDED FOR NEW DESIGN

## Functional Description

### PWM Control

The AP5002 consists of DC/DC converters that employ a pulse-width modulation (PWM) system. In converters of the AP5002, the pulse width varies in a range up to 100%, according to the load current. The ripple voltage produced by the switching can easily be removed through a filter because the switching frequency remains constant. Therefore, these converters provide a low-ripple power over broad ranges of input voltage and load current.

### R<sub>DS(ON)</sub> Current Limiting

The current limit threshold is set by the internal circuit.

### Setting the Output Voltage

Application circuit item shows the basic application circuit with adjustable output version. The external resistor sets the output voltage according to the following equation:

V <sub>OUT</sub> (V)	R1 (KΩ)	R2 (KΩ)
5	6.4	1.2
3.3	3.8	1.2
2.5	2.6	1.2
1.8	3.3	2.6
1.5	3.3	3.7
1.2	3.3	6.5
1	3.3	13

### Inductor Selection

For most designs, the operates with inductors of 10μH to 22μH. The inductor value can be derived from the following equation:

$$L = \frac{(V_{IN} - V_{OUT})T_{ON}}{2 \times \Delta I_L \times f_{osc}}$$

Where is inductor Ripple Current. Large value inductors lower ripple current and small value inductors result in high ripple currents. Choose inductor ripple current approximately 15% of the maximum load current 2A, ΔI<sub>L</sub>=0.3A. The DC current rating of the inductor should be at least equal to the maximum load current plus half the ripple current to prevent core saturation (2A+0.15A).

### Input Capacitor Selection

#### EL CAP

This capacitor should be located close to the IC using short leads and the voltage rating should be approximately 1.5 times the maximum input voltage. The RMS current rating requirement for the input capacitor of a buck regulator is approximately 1/2 the DC load current. A low ESR input capacitor sized for maximum RMS current must be used. A 470μF low ESR capacitor for most applications is sufficient.

#### MLCC CAP

A 22μF MLCC capacitor for most applications is sufficient.

### Output Capacitor Selection

#### EL CAP

The output capacitor is required to filter the output voltage and provides regulator loop stability. The important capacitor parameters are the 100KHz Equivalent Series Resistance (ESR), the RMS ripples current rating, voltage rating and capacitance value. For the output capacitor, the ESR value is the most important parameter. The output ripple can be calculated from the following formula.

$$V_{RIPPLE} = \Delta I_L \times ESR$$

The bulk capacitor's ESR will determine the output ripple voltage and the initial voltage drop after a high slew-rate transient.

An aluminum electrolytic capacitor's ESR value is related to the capacitance and its voltage rating. In most case, higher voltage electrolytic capacitors have lower ESR values. Most of the time, capacitors with much higher voltage ratings may be needed to provide the low ESR values required for low output ripple voltage.

#### MLCC CAP

A 22μF MLCC capacitor for most applications is sufficient.

### PCB Layout Guide

If you need low T<sub>C</sub> & T<sub>J</sub> or large PD(Power Dissipation), The dual SW pins(5& 6) and V<sub>SS</sub> pins(7& 8) on the SOP-8L package are internally connected to die pad, The PCB layout should allow for maximum possible copper area at the SW pins.

1. Connect C3 to V<sub>CC</sub> and V<sub>SS</sub> pin as closely as possible to get good power filter effect.
2. Connect R4 to V<sub>CC</sub> and OCSET pin as closely as possible.
3. Connect ground side of the C2 & D1 as closely as possible.

**Functional Description** (continued)

Typical PC Board Layout

**Top Side Layout Guide**

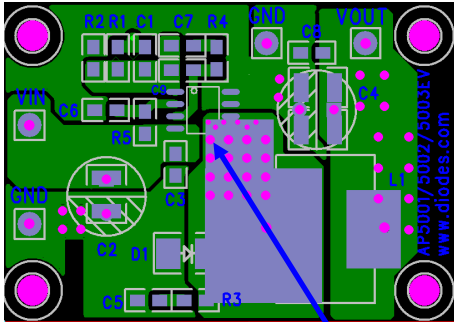

Use vias to conduct the heat into the backside of PCB layer. The PCB heat sink copper area should be solder-painted without masked. This approaches a "best case" pad heat sink.

**Bottom Side Layout Guide**

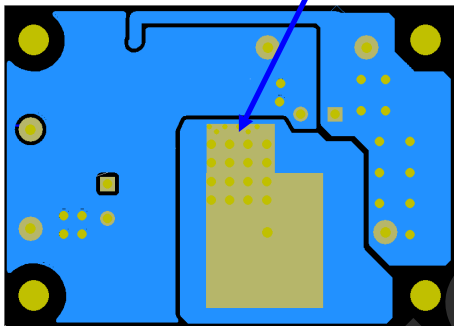

NOT RECOMMENDED FOR NEW DESIGN

**Ordering Information**

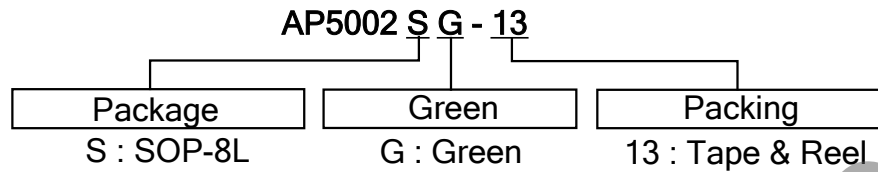

Device	Package Code	Packaging (Note 3)	13" Tape and Reel	
			Quantity	Part Number Suffix
AP5002SG-13	S	SOP-8L	2500/Tape & Reel	-13

Note: 3. Pad layout as shown in Diodes Incorporated's package outline PDFs, which can be found on our website at <http://www.diodes.com/package-outlines.html>.

**Marking Information**

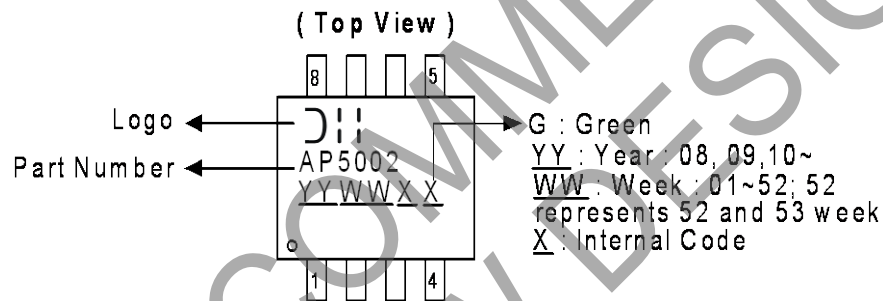

NOT RECOMMENDED FOR NEW DESIGN

**Package Outline Dimensions** (All Dimensions in mm)

Please see <http://www.diodes.com/package-outlines.html> for the latest version.

(1) Package type: SOP-8L

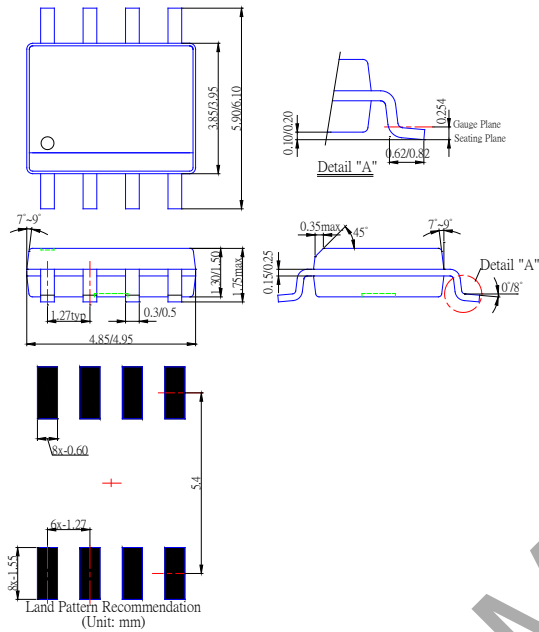

NOT RECOMMENDED FOR NEW DESIGN

**IMPORTANT NOTICE**

DIODES INCORPORATED MAKES NO WARRANTY OF ANY KIND, EXPRESS OR IMPLIED, WITH REGARDS TO THIS DOCUMENT, INCLUDING, BUT NOT LIMITED TO, THE IMPLIED WARRANTIES OF MERCHANTABILITY AND FITNESS FOR A PARTICULAR PURPOSE (AND THEIR EQUIVALENTS UNDER THE LAWS OF ANY JURISDICTION).

Diodes Incorporated and its subsidiaries reserve the right to make modifications, enhancements, improvements, corrections or other changes without further notice to this document and any product described herein. Diodes Incorporated does not assume any liability arising out of the application or use of this document or any product described herein; neither does Diodes Incorporated convey any license under its patent or trademark rights, nor the rights of others. Any Customer or user of this document or products described herein in such applications shall assume all risks of such use and will agree to hold Diodes Incorporated and all the companies whose products are represented on Diodes Incorporated website, harmless against all damages.

Diodes Incorporated does not warrant or accept any liability whatsoever in respect of any products purchased through unauthorized sales channel. Should Customers purchase or use Diodes Incorporated products for any unintended or unauthorized application, Customers shall indemnify and hold Diodes Incorporated and its representatives harmless against all claims, damages, expenses, and attorney fees arising out of, directly or indirectly, any claim of personal injury or death associated with such unintended or unauthorized application.

Products described herein may be covered by one or more United States, international or foreign patents pending. Product names and markings noted herein may also be covered by one or more United States, international or foreign trademarks.

This document is written in English but may be translated into multiple languages for reference. Only the English version of this document is the final and determinative format released by Diodes Incorporated.

**LIFE SUPPORT**

Diodes Incorporated products are specifically not authorized for use as critical components in life support devices or systems without the express written approval of the Chief Executive Officer of Diodes Incorporated. As used herein:

A. Life support devices or systems are devices or systems which:

1. are intended to implant into the body, or
2. support or sustain life and whose failure to perform when properly used in accordance with instructions for use provided in the labeling can be reasonably expected to result in significant injury to the user.

B. A critical component is any component in a life support device or system whose failure to perform can be reasonably expected to cause the failure of the life support device or to affect its safety or effectiveness.

Customers represent that they have all necessary expertise in the safety and regulatory ramifications of their life support devices or systems, and acknowledge and agree that they are solely responsible for all legal, regulatory and safety-related requirements concerning their products and any use of Diodes Incorporated products in such safety-critical, life support devices or systems, notwithstanding any devices- or systems-related information or support that may be provided by Diodes Incorporated. Further, Customers must fully indemnify Diodes Incorporated and its representatives against any damages arising out of the use of Diodes Incorporated products in such safety-critical, life support devices or systems.

Copyright © 2020, Diodes Incorporated

[www.diodes.com](http://www.diodes.com)